

Status and future of SOLEIL Fast Orbit Feedback

Romain Bronès, A. Bence, N. Hubert, G. Pichon, D. Pédeau - DEELS '24

- ▶ Integration to the Control System and commissioning
- ▶ New identification features
- ▶ Future of the Sniffer Archiver

Integration to the Control System and commissioning



- ▶ BPM data collected and forwarded to Central Node
- ▶ Correction data distributed back to PSC
- ▶ Tested and reported last year (IBIC'23)

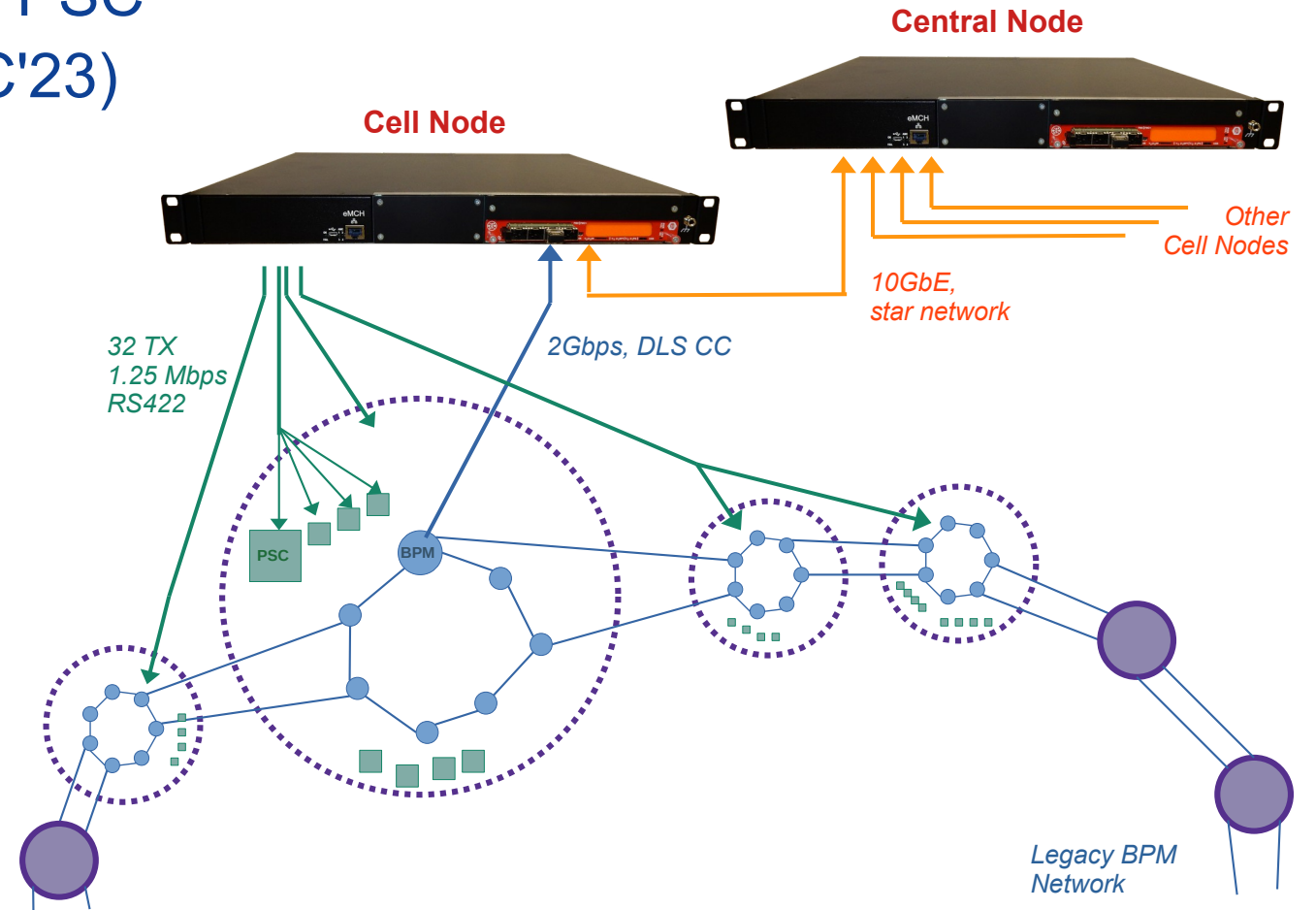
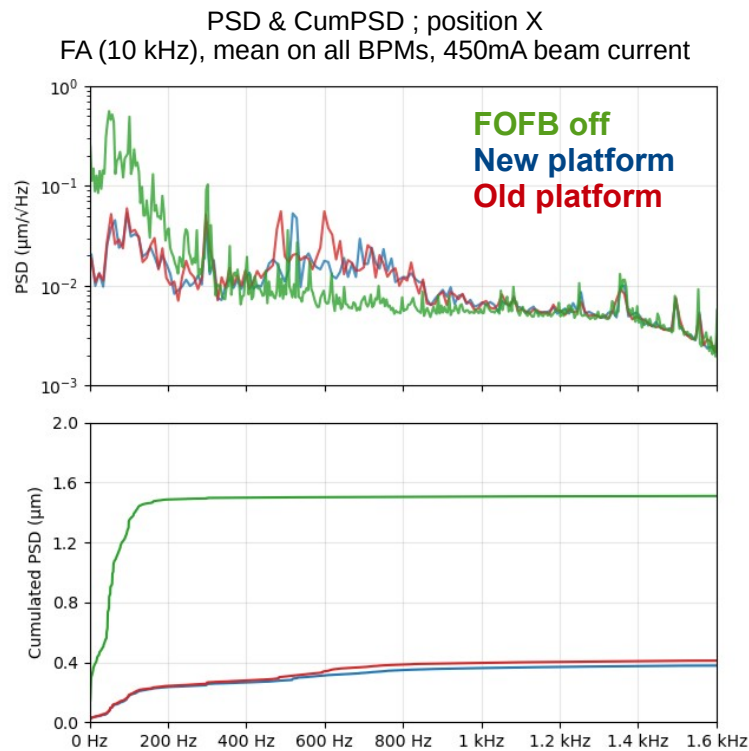

► Original Tango device : Fofb-Manager

- ▽ Big, complete software with multitask
- ▽ Shaped for Libera Electron (write registers with "magic values")
- ▽ Has an inside state machine
- ▽ Hard to modify

► What's required at the Control System Level

- ▽ Get the system state
- ▽ Manual actions: start, stop, configure
- ▽ Automatic action: stop
- ▽ Driving from original Matlab GUI must be kept

► Linking FofbNodes to Tango

- ▽ Generic ChimeraTK application, running on the SoC
Polls FPGA registers but notify clients only if value change
- ▽ Client is a generic Tango device, running on the Control System server

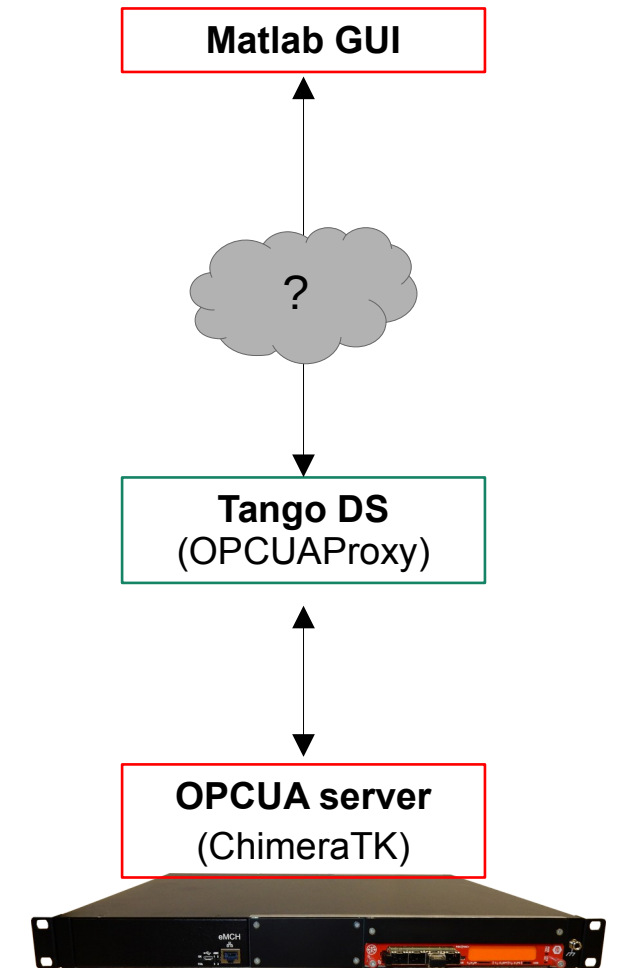

Tango devices for Control & Monitor

► FofbWatcher

- ▷ Composes the system state (booleans) from attributes of several devices. Not a state machine !
- ▷ Boolean operation are configured via properties
- ▷ Log and send event on boolean change
- ▷ One stop place to get a picture of the system state

FOFBWatcher, properties highlights

Property name	Value
DefaultTaskPeriod	100
Device_CellNodes	test/dg/fofb.cellnode-C01.subscriber test/dg/fofb.cellnode-C06.subscriber test/dg/fofb.cellnode-C09.subscriber test/dg/fofb.cellnode-C14.subscriber test/dg/fofb.nub.tester test/dg/fofb.centralnode.subscriber
Device_CentralNode	test/dg/fofb.centralnode.subscriber
Device_DCCTLifeTime	ans/dg/dcct-ctrl
Device_Hsteerers	FREE_PROPERTY:FOFBHSteererList
Device_Vsteerers	FREE_PROPERTY:FOFBVSteererList
InhibitedDevice_Hsteerers	
Inhibit_bpmX	63 0 123 124 125 126 127
Inhibit_bpmY	63 0 123 124 125 126 127
Inhibit_CorrX	
Inhibit_CorrY	
Period_CorrectorCmdX	500
Period_CorrectorCmdY	500
Period_OrbitErrorX	500
Period_OrbitErrorY	500
SeparatorProperties	
Tests_List_Prop	BeamStored;ThresholdDouble;DCCTLifeTime;current;Threshold_BeamCurrent;> ComSteerer;ThresholdDouble;Hsteerers;state;Threshold_SteererState;=> ComSteerer;ThresholdDouble;Vsteerers;state;Threshold_SteererState;=> ComSteerer;ThresholdDouble;Hsteerers;nbframesec;Threshold_FofbRate;> ComSteerer;ThresholdDouble;Vsteerers;nbframesec;Threshold_FofbRate;> ComBpmCellNode;ThresholdDouble;CellNodes;combpm_protocol_status;Threshold_ComBpmStatus;=> ComCellNode;ThresholdDouble;CellNodes;ccneth0_rx_framerate;Threshold_FofbRate;> OrbitErrorX;ThresholdDouble;CentralNode;orbit_error_x;Threshold_OrbitErrorX;a<;INHIBITED_INDEXES_PROP=Inhibit_bpmX;MAX_FAILURE=5 OrbitErrorY;ThresholdDouble;CentralNode;orbit_error_y;Threshold_OrbitErrorY;a<;INHIBITED_INDEXES_PROP=Inhibit_bpmY;MAX_FAILURE=5

FOFBWatcher, attributes and status

Tango devices for Control & Monitor

► FofbWatcher

► FofbCommand

- ▷ Runs pre-defined operations
- ▷ Hold and transmit the Inverted Response Matrix, orbit reference
- ▷ Act automatically or on user demand
- ▷ Receives events from the FofbWatcher
- ▷ Can condition actions with FofbWatcher booleans

FOFBCommand, attributes and status

AtkPanel 5.9 : test/dg/fofbcommand (on rcm2.rcm)

File View Preferences Help

test/dg/fofbcommand StartFOFB_X

test/dg/fofbcommand
FOFB state: RUNNING X

FOFB startable	<input checked="" type="checkbox"/>	...
last x inv resp mat loading time	2023-12-11 16:13:55	...
last y inv resp mat loading time	2023-12-11 16:13:55	...
last x ref orbit loading time	2023-12-12 15:33:34	...
last y ref orbit loading time	2023-12-12 13:51:54	...

Scalar log x_ref_orbit y_ref_orbit x_inv_resp_mat y_inv_resp_mat

Tango devices for Control & Monitor

- ▶ FofbWatcher
- ▶ FofbCommand
- ▶ FofbLegacy
 - Attribute/command translator to adapt Matlab GUI
- ▶ FofbTool
 - Python module
 - Expert tool for configuration
 - inter FofbNode communication bring up

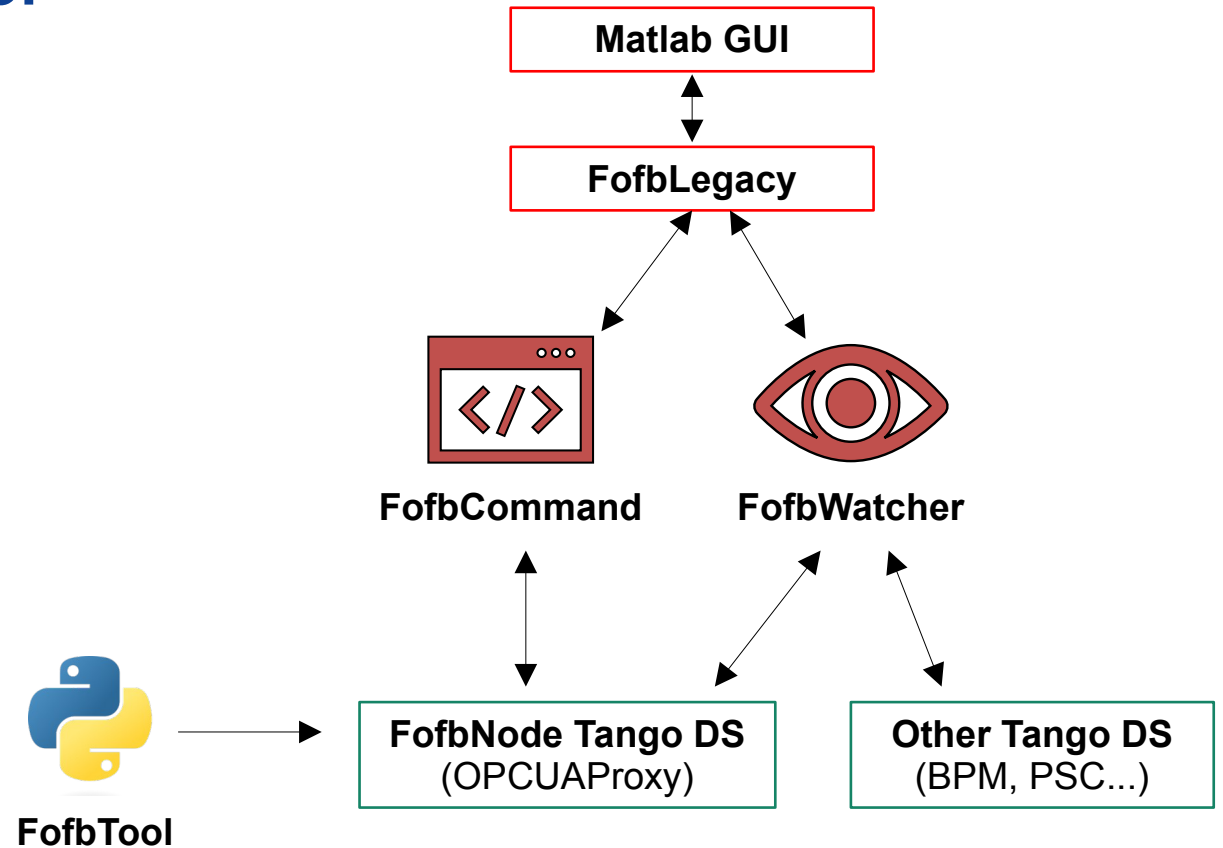

- ▶ Final test on a dedicated machine shift 29/01
- ▶ Followed by a production test week
 - Quick fallback to Libera Based system (tango proxy, relay switches)
- ▶ On-Duty call exercises for the team
- ▶ Few incidents since
 - FofbWatcher a little more sensitive to Tango Read hangs on Steerer devices
→ Auto stop, solved by a simple "start"
- ▶ Very transparent for the operation team
 - Same Matlab GUI
- ▶ Pending test on log handler system
 - Based on ElasticSearch

New identification features



► Transfer function measure

- ▷ Input: Sine waveform drives the PSC, 40Hz – 1600Hz
- ▷ Output: Position data from the 60 most sensitive BPM, normalized by ORM
- ▷ 3 groups: Nominal (blues) ; Injection (reds) ; Close-by Invar (greens)

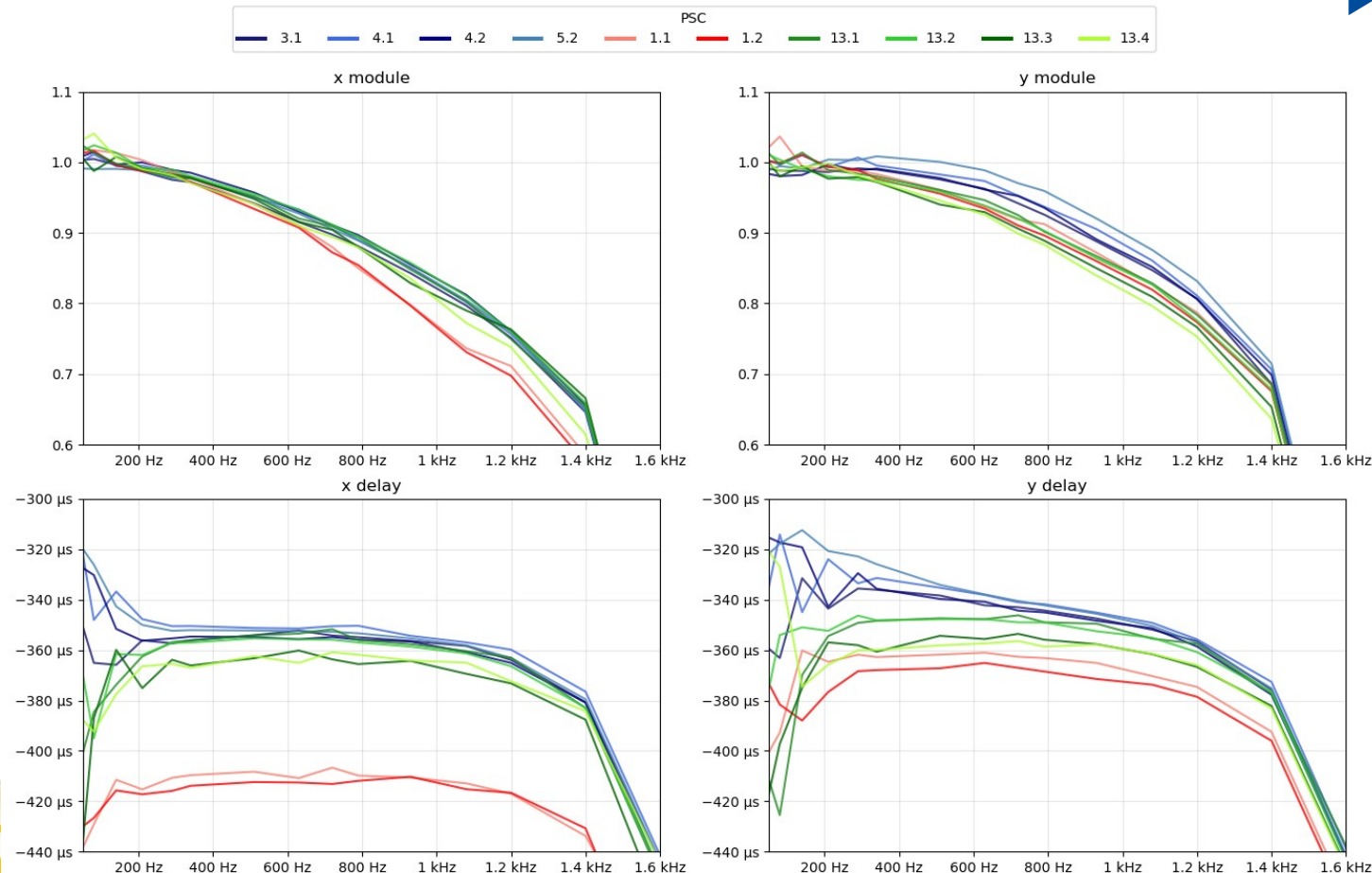

► Observations

- ▷ Injection section PSC show additional X/Y delay 55/25 μs ; lesser gain above 600/300 Hz
These magnets are on stainless steel beampipe (not on bellows)
- ▷ Some close-by Invar PSC show additional X/Y delay of about 10 μs .
- ▷ Y delay of nominal PSC show a phase shift, whereas other are flatter.
- ▷ Delay result disturbed under 150Hz. Probably because of noisy band.
- ▷ Strong diversity of module shape: This is challenging for fast ORM measure.

► Fast ORM measure

- ▷ "Slow" measure: 1 PSC at a time, (time multiplexing). 18 minutes.
- ▷ "Fast" measure: (add Frequency mutliplexing) 10 PSC at a time, each on at a narrow frequency in band 200-400 Hz 2 minutes.

► Tackle module diversity in 200-400 Hz band

- ▷ Make 2 measures, each PSC will be measured at a different frequency.
- ▷ Interpolate results at a unique frequency point.

► Assessing reproducibility of Slow/Fast measure

- ▷ 4 observations for each method
- ▷ For each coefficient, compute peak to peak of observations.
- ▷ Work per quadrants, units in $\mu\text{m}/\text{A}$
- ▷ Unexplained differences X/Y for slow method

► Change methodology: consider ORM as an operator ?

BPM	X	Y
PSC		
X	S: 1.8 F: 0.5	S: 0.3 F: 1
Y	S: 1.3 F: 0.6	S: 0.3 F: 0.7

Worst peak to peak coefficient observation, for Slow/Fast method ($\mu\text{m}/\text{A}$)

BPM	X	Y
PSC		
X	64	4
Y	4	27

Max coefficient magnitude for each quadrant ($\mu\text{m}/\text{A}$)

Future of the Sniffer Archiver



▶ Current Sniffer Archiver decommissioned soon

- ▷ As soon as the legacy ring network is emptied of BPM (2025)

▶ Future Sniffer Archiver

- ▷ Ingest position, correction and sum data from the CentralNode
- ▷ Ease event search: localize trigger
- ▷ Machine evolution
10→100 kHz data rate ; +65% BPMs ; +20% PSC
- ▷ Leads to data throughput & volume tenfolding
16 to 280 MBytes/s ; Daily volume from 1.4 to 24 TB

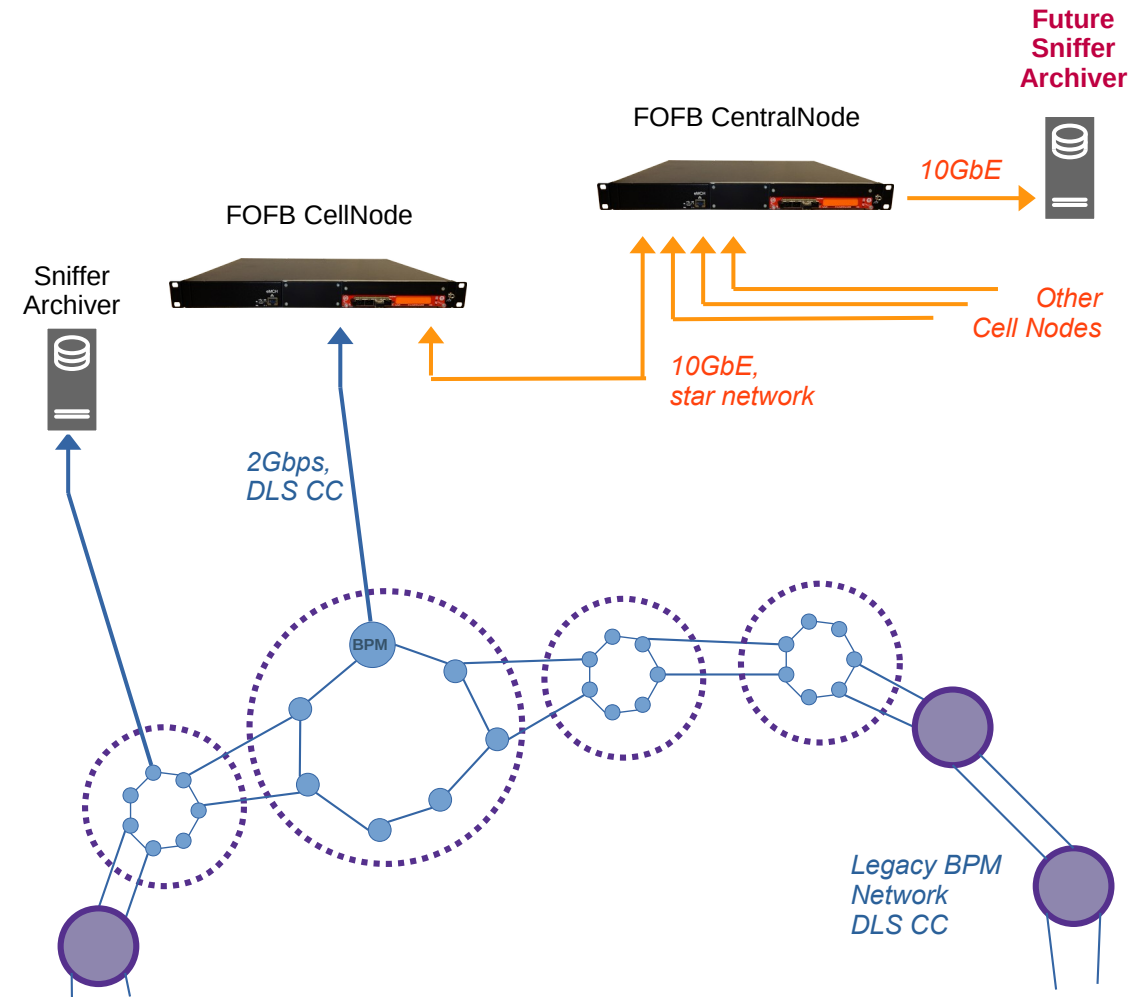

- ▶ Discussion started with DLS, ALBA, MAX IV, ESRF
- ▶ Two options for SOLEIL
- ▶ Option 1: Update the Sniffer
 - Use 10GbE interface, UDP socket
 - BPMid → id (BPM, sum, corr, timing)
 - Increase storage
- ▶ Option 2: Generalized solution
 - UDP socket server
 - Pushing data to file / Timeseries DataBase

→ Common next step:
CentralNode outputs UDP frames



Thank you !

